



16-BIT 250-KSPS SERIAL CMOS SAMPLING ANALOG-TO-DIGITAL CONVERTER

FEATURES

- 250-kHz Sampling Rate
- 4-V, 5-V, 10-V, ± 3.33 -V, ± 5 -V, and ± 10 -V Input Ranges
- ± 2 LSB Max INL
- ± 1 LSB Max DNL, 16-Bit No Missing Codes
- SPI Compatible Serial Output with Daisy-Chain (TAG) Feature
- Single 5-V Supply
- Pin-Compatible with ADS7809 (Low Speed) and 12-Bit ADS8508/7808
- Uses Internal or External Reference
- 70-mW Typ Power Dissipation at 250 KSPS
- 20-Pin SO and 28-Pin SSOP Packages
- Simple DSP Interface

APPLICATIONS

- Industrial Process Control
- Data Acquisition Systems
- Digital Signal Processing
- Medical Equipment
- Instrumentation

DESCRIPTION

The ADS8509 is a complete 16-bit sampling analog-to-digital (A/D) converter using state-of-the-art CMOS structures. It contains a complete 16-bit, capacitor-based, successive approximation register (SAR) A/D converter with sample-and-hold, reference, clock, and a serial data interface. Data can be output using the internal clock or can be synchronized to an external data clock. The ADS8509 also provides an output synchronization pulse for ease of use with standard DSP processors.

The ADS8509 is specified at a 250-kHz sampling rate over the full temperature range. Precision resistors provide various input ranges including ± 10 V and 0 V to 5 V, while the innovative design allows operation from a single +5-V supply with power dissipation under 100 mW.

The ADS8509 is available in 20-pin SO and 28-pin SSOP packages, both fully specified for operation over the industrial -40°C to 85°C temperature range.

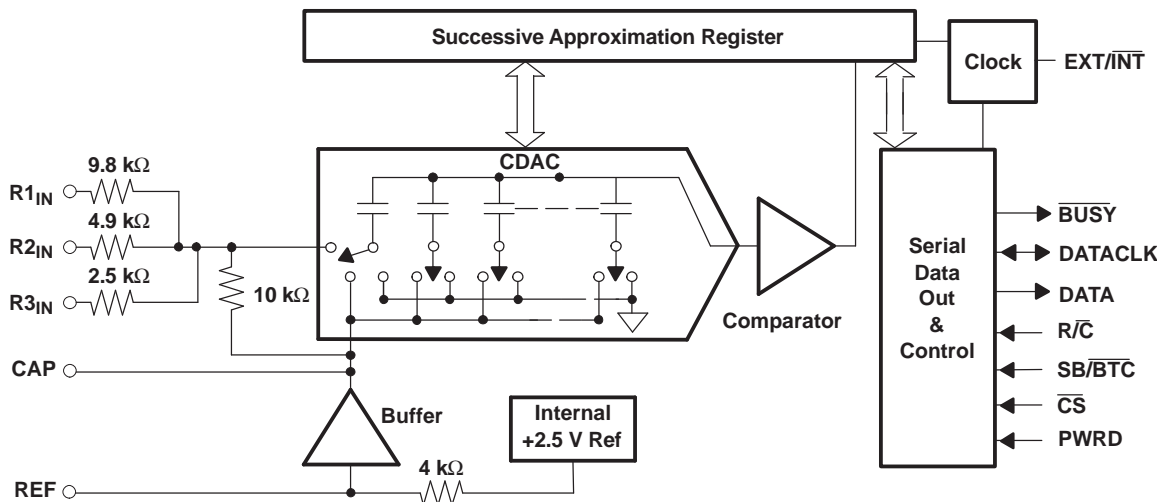

Please be aware that an important notice concerning availability, standard warranty, and use in critical applications of Texas Instruments semiconductor products and disclaimers thereto appears at the end of this data sheet.



These devices have limited built-in ESD protection. The leads should be shorted together or the device placed in conductive foam during storage or handling to prevent electrostatic damage to the MOS gates.

PACKAGE/ORDERING INFORMATION⁽¹⁾

PRODUCT	MINIMUM RELATIVE ACCURACY (LSB)	NO MISSING CODE	MINIMUM SINAD (dB)	SPECIFICATION TEMPERATURE RANGE	PACKAGE LEAD	PACKAGE DESIGNATOR	ORDERING NUMBER	TRANSPORT MEDIA, QTY
ADS8509IB	±2	16	85	-40°C to 85°C	SO-20	DW	ADS8509IBDW	Tube, 25
							ADS8509IBDWR	Tape and Reel, 2000
					SSOP-28	DB	ADS8509IBDB	Tube, 50
							ADS8509IBDBR	Tape and Reel, 2000
ADS8509I	±3	15	83	-40°C to 85°C	SO-20	DW	ADS8509IDW	Tube, 25
							ADS8509IDWR	Tape and Reel, 2000
					SSOP-28	DB	ADS8509IDB	Tube, 50
							ADS8509IDBR	Tape and Reel, 2000

(1) For the most current package and ordering information, see the Package Option Addendum at the end of this document, or see the TI website at www.ti.com.

ABSOLUTE MAXIMUM RATINGS

over operating free-air temperature range (unless otherwise noted)⁽¹⁾

		UNIT
Analog inputs	R _{1IN}	±25 V
	R _{2IN}	±25 V
	R _{3IN}	±25 V
	REF	+V _{ANA} + 0.3 V to AGND2 - 0.3 V
	CAP	Indefinite short to AGND2, momentary short to V _{ANA}
Ground voltage differences	DGND, AGND2	±0.3 V
	V _{ANA}	6 V
	V _{DIG} to V _{ANA}	0.3 V
	V _{DIG}	6 V
Digital inputs		-0.3 V to +V _{DIG} + 0.3 V
Maximum junction temperature		165°C
Storage temperature range		-65°C to 150°C
Internal power dissipation		700 mW
Lead temperature (soldering, 1.6 mm from case 10 seconds)		260°C

(1) All voltage values are with respect to network ground terminal.

ELECTRICAL CHARACTERISTICS

At $T_A = -40^\circ\text{C}$ to 85°C , $f_s = 250\text{ kHz}$, $V_{\text{DIG}} = V_{\text{ANA}} = 5\text{ V}$, using internal reference and 0.1%, 0.25-W fixed resistors (see Figure 29 and Figure 30) (unless otherwise specified)

PARAMETER	TEST CONDITIONS	ADS8509I			ADS8509IB			UNIT
		MIN	TYP	MAX	MIN	TYP	MAX	
Resolution				16			16	Bits
ANALOG INPUT								
Voltage range ⁽¹⁾								
Impedance ⁽¹⁾								
Capacitance			50			50		pF
THROUGHPUT SPEED								
Conversion cycle	Acquire and convert			4			4	μs
Throughput rate		250			250			kHz
DC ACCURACY								
INL	Integral linearity error		-3	3	-2		2	LSB ⁽²⁾
DNL	Differential linearity error		-2	2	-1		1	LSB
	No missing codes		15		16			Bits
	Transition noise ⁽³⁾		1		1			LSB
Full-scale error ⁽⁴⁾⁽⁵⁾	±10-V Range	Int. ref. with 0.1% external fixed resistors	-0.5	0.5	-0.5		0.5	%FSR
	All other ranges		-0.5	0.5	-0.5	0.5		
	Full-scale error drift	Int. ref.	±7		±7			ppm/°C
Full-scale error ⁽⁴⁾⁽⁵⁾	±10-V Range	Ext. ref. with 0.1% external fixed resistors	-0.5	0.5	-0.5		0.5	%FSR
	All other ranges		-0.5	0.5	-0.5	0.5		
	Full-scale error drift	Ext. ref.	±2		±2			ppm/°C
	Bipolar zero error ⁽⁴⁾		-10	10	-5		5	mV
	Bipolar zero error drift		±0.4		±0.4			ppm/°C
Unipolar zero error ⁽⁴⁾	10-V Range		-5	5	-5		5	mV
	4-V and 5-V Range		-3	3	-3		3	
	Unipolar zero error drift		±2		±2			ppm/°C
	Recovery to rated accuracy after power down	1-μF Capacitor to CAP	1		1			ms
	Power supply sensitivity ($V_{\text{DIG}} = V_{\text{ANA}} = V_{\text{D}}$)	+4.75 V < V_{D} < +5.25 V	-8	8	-8		8	LSB
AC ACCURACY								
SFDR	Spurious-free dynamic range	$f_1 = 20\text{ kHz}$	90	99	95	99		dB ⁽⁶⁾
THD	Total harmonic distortion	$f_1 = 20\text{ kHz}$		-98	-90		-98	dB
SINAD	Signal-to-(noise+distortion)	$f_1 = 20\text{ kHz}$	83	88	85	88		dB
		-60-dB Input		30		32		dB
SNR	Signal-to-noise ratio	$f_1 = 20\text{ kHz}$	83	88	86	88		dB
	Full-power bandwidth ⁽⁷⁾		500		500			kHz
SAMPLING DYNAMICS								
	Aperture delay		5		5			ns
	Transient response	FS Step	2		2			μs
	Overvoltage recovery ⁽⁸⁾		150		150			ns

- (1) ±10 V, 0 V to 5 V, etc. (see Table 3). For normal operation, the analog input should not exceed configured range ±20%.
- (2) LSB means least significant bit. For the ±10-V input range, one LSB is 305 μV.
- (3) Typical rms noise at worst case transitions and temperatures.
- (4) As measured with fixed resistors shown in Figure 29 and Figure 30. Adjustable to zero with external potentiometer. Factory calibrated with 0.1%, 0.25-W resistors.
- (5) For bipolar input ranges, full-scale error is the worst case of -full-scale or +full-scale uncalibrated deviation from ideal first and last code transitions, divided by the transition voltage (not divided by the full-scale range) and includes the effect of offset error. For unipolar input ranges, full-scale error is the deviation of the last code transition divided by the transition voltage. It also includes the effect of offset error.
- (6) All specifications in dB are referred to a full-scale ±10-V input.
- (7) Full-power bandwidth is defined as the full-scale input frequency at which signal-to-(noise + distortion) degrades to 60 dB.
- (8) Recovers to specified performance after 2 x FS input overvoltage.

ELECTRICAL CHARACTERISTICS (continued)

At $T_A = -40^{\circ}\text{C}$ to 85°C , $f_s = 250\text{ kHz}$, $V_{\text{DIG}} = V_{\text{ANA}} = 5\text{ V}$, using internal reference and 0.1%, 0.25-W fixed resistors (see Figure 29 and Figure 30) (unless otherwise specified)

PARAMETER	TEST CONDITIONS	ADS8509I			ADS8509IB			UNIT
		MIN	TYP	MAX	MIN	TYP	MAX	
REFERENCE								
Internal reference voltage	No load	2.48	2.5	2.52	2.48	2.5	2.52	V
Internal reference source current (must use external buffer)		1			1			μA
Internal reference drift		8			8			ppm/ $^{\circ}\text{C}$
External reference voltage range for specified linearity		2.3	2.5	2.7	2.3	2.5	2.7	V
External reference current drain	Ext. 2.5-V ref.	100			100			μA
DIGITAL INPUTS								
Logic levels								
V_{IL} Low-level input voltage		-0.3		0.8	-0.3		0.8	V
V_{IH} High-level input voltage		2.0		$V_{\text{DIG}} + 0.3\text{ V}$	2.0		$V_{\text{DIG}} + 0.3\text{ V}$	V
I_{IL} Low-level input current	$V_{\text{IL}} = 0\text{ V}$			± 10			± 10	μA
I_{IH} High-level input current	$V_{\text{IH}} = 5\text{ V}$			± 10			± 10	μA
DIGITAL OUTPUTS								
Data format (serial 16-bits)								
Data coding (binary 2's complement or straight binary)								
Pipeline delay (conversion results only available after completed conversion)								
Data clock (selectable for internal or external data clock)								
Internal clock (output only when transmitting data)	EXT/ $\overline{\text{INT}}$ Low		9			9		MHz
External clock (can run continually but not recommended for optimum performance)	EXT/ $\overline{\text{INT}}$ High	0.1		26	0.1		26	MHz
V_{OL} Low-level output voltage	$I_{\text{SINK}} = 1.6\text{ mA}$			0.4			0.4	V
V_{OH} High-level output voltage	$I_{\text{SOURCE}} = 500\text{ }\mu\text{A}$	4			4			V
Leakage current	Hi-Z State, $V_{\text{OUT}} = 0\text{ V}$ to V_{DIG}			± 5			± 5	μA
Output capacitance	Hi-Z State			15			15	pF
POWER SUPPLIES								
V_{DIG} Digital input voltage	Must be $\leq V_{\text{ANA}}$	4.75	5	5.25	4.75	5	5.25	V
V_{ANA} Analog input voltage		4.75	5	5.25	4.75	5	5.25	V
I_{DIG} Digital input current		4			4			mA
I_{ANA} Analog input current		10			10			mA
POWER DISSIPATION								
PWRD Low	$f_s = 250\text{ kHz}$		70	100		70	100	mW
PWRD High			50			50		μW
TEMPERATURE RANGE								
Specified performance		-40		85	-40		85	$^{\circ}\text{C}$
Derated performance ⁽⁹⁾		-55		125	-55		125	$^{\circ}\text{C}$
Storage		-65		150	-65		150	$^{\circ}\text{C}$
THERMAL RESISTANCE (θ_{JA})								
SSOP			62			62		$^{\circ}\text{C/W}$
SO			46			46		$^{\circ}\text{C/W}$

(9) The internal reference may not be started correctly beyond the industrial temperature range (-40°C to 85°C), therefore use of an external reference is recommended.

TIMING REQUIREMENTS, $T_A = -40^{\circ}\text{C}$ to 85°C

PARAMETER		MIN	TYP	MAX	UNIT
t_{w1}	Pulse duration, convert	40			ns
t_{d1}	Delay time, $\overline{\text{BUSY}}$ from R/C low		6	20	ns
t_{w2}	Pulse duration, $\overline{\text{BUSY}}$ low			2.2	μs
t_{d2}	Delay time, $\overline{\text{BUSY}}$, after end of conversion		5		ns
t_{d3}	Delay time, aperture		5		ns
t_{conv}	Conversion time			2.2	μs
t_{acq}	Acquisition time	1.8			μs
$t_{\text{conv}} + t_{\text{acq}}$	Cycle time			4	μs
t_{d4}	Delay time, R/C low to internal DATACLK output		270		ns
t_{c1}	Cycle time, internal DATACLK		110		ns
t_{d5}	Delay time, data valid to internal DATACLK high	15	35		ns
t_{d6}	Delay time, data valid after internal DATACLK low	20	35		ns
t_{c2}	Cycle time, external DATACLK	35			ns
t_{w3}	Pulse duration, external DATACLK high	15			ns
t_{w4}	Pulse duration, external DATACLK low	15			ns
$t_{\text{su}1}$	Setup time, R/C rise/fall to external DATACLK high	15			ns
$t_{\text{su}2}$	Setup time, R/C transition to $\overline{\text{CS}}$ transition	10			ns
t_{d7}	Delay time, SYNC, after external DATACLK high	3		35	ns
t_{d8}	Delay time, data valid	2		20	ns
t_{d9}	Delay time, $\overline{\text{CS}}$ to rising edge	10			ns
t_{d10}	Delay time, previous data available after $\overline{\text{CS}}$, R/C low	2			μs
$t_{\text{su}3}$	Setup time, $\overline{\text{BUSY}}$ transition to first external DATACLK	5			ns
t_{d11}	Delay time, final external DATACLK to $\overline{\text{BUSY}}$ falling edge			1	μs
$t_{\text{su}3}$	Setup time, TAG valid	0			ns
t_{h1}	Hold time, TAG valid	2			ns

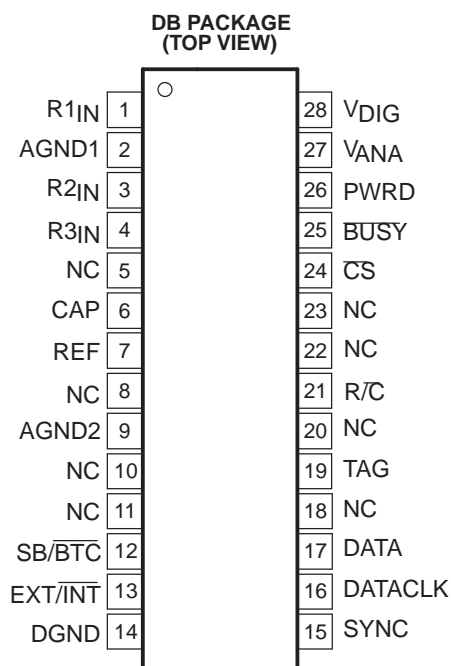
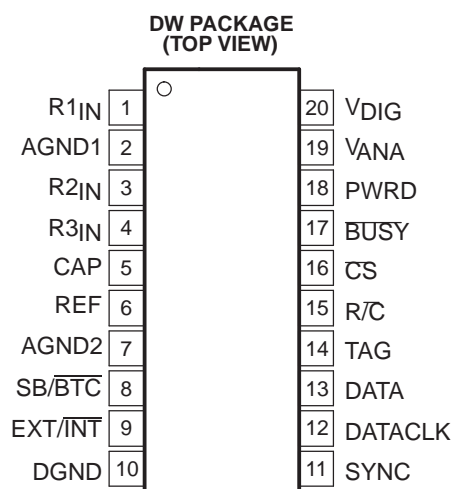

Terminal Functions

TERMINAL				DESCRIPTION
NAME	DB NO.	DW NO.	I/O	
AGND1	2	2	–	Analog ground. Used internally as ground reference point. Minimal current flow.
AGND2	9	7	–	Analog ground
BUSY	25	17	O	Busy output. Falls when a conversion is started and remains low until the conversion is completed and the data is latched into the output shift register.
CAP	6	5	–	Reference buffer capacitor. 2.2- μ F Tantalum to ground.
\overline{CS}	24	16	–	Chip select. Internally ORed with R/\overline{C} .
DATA	17	13	O	Serial data output. Data is synchronized to DATACLK with the format determined by the level of SB/BTC. In the external clock mode, after 16 bits of data, the ADS8509 outputs the level input on TAG as long as \overline{CS} is low and R/\overline{C} is high (see Figure 8 and Figure 9). If EXT/ \overline{INT} is low, data is valid on both the rising and falling edges of DATACLK, and between conversions DATA stays at the level of the TAG input when the conversion was started.
DATACLK	16	12	I/O	Either an input or an output depending on the EXT/ \overline{INT} level. Output data is synchronized to this clock. If EXT/ \overline{INT} is low, DATACLK transmits 16 pulses after each conversion and then remains low between conversions.
DGND	14	10	–	Digital ground
EXT/ \overline{INT}	13	9	–	Selects external or internal clock for transmitting data. If high, data is output synchronized to the clock input on DATACLK. If low, a convert command initiates the transmission of the data from the previous conversion, along with 16-clock pulses output on DATACLK.
NC	5, 8, 10, 11, 18, 20, 22, 23	–	–	No connect
PWRD	26	18	I	Power down input. If high, conversions are inhibited and power consumption is significantly reduced. Results from the previous conversion are maintained in the output shift register.
R/\overline{C}	21	15	I	Read/convert input. With \overline{CS} low, a falling edge on R/\overline{C} puts the internal sample-and-hold into the hold state and starts a conversion. When EXT/ \overline{INT} is low, this also initiates the transmission of the data results from the previous conversion. If EXT/ \overline{INT} is high, a rising edge on R/\overline{C} with \overline{CS} low or a falling edge on \overline{CS} with R/\overline{C} high transmits a pulse on SYNC and initiates the transmission of data from the previous conversion.
REF	7	6	I/O	Reference input/output. Outputs internal 2.5-V reference. Can also be driven by external system reference. In both cases, bypass to ground with a 2.2- μ F tantalum capacitor.
R1 _{IN}	1	1	I	Analog input. See Table 3 for input range connections.
R2 _{IN}	3	3	I	Analog input. See Table 3 for input range connections.
R3 _{IN}	4	4	I	Analog input. See Table 3 for input range connections.
SB/BTC	12	8	O	Select straight binary or binary 2's complement data output format. If high, data is output in a straight binary format. If low, data is output in a binary 2's complement format.
SYNC	15	11	O	Sync output. This pin is used to supply a data synchronization pulse when the EXT level is high and at least one external clock pulse has occurred when not in the read mode. See the external clock modes descriptions.
TAG	19	14	I	Tag input for use in the external clock mode. If EXT is high, digital data input from TAG is output on DATA with a delay that is dependent on the external clock mode. See Figure 8 and Figure 9.
V _{ANA}	27	19	I	Analog supply input. Nominally +5 V. Connect directly to pin 20 and decouple to ground with 0.1- μ F ceramic and 10- μ F tantalum capacitors.
V _{DIG}	28	20	I	Digital supply input. Nominally +5 V. Connect directly to pin 19. Must be $\leq V_{ANA}$.

PARAMETER MEASUREMENT INFORMATION

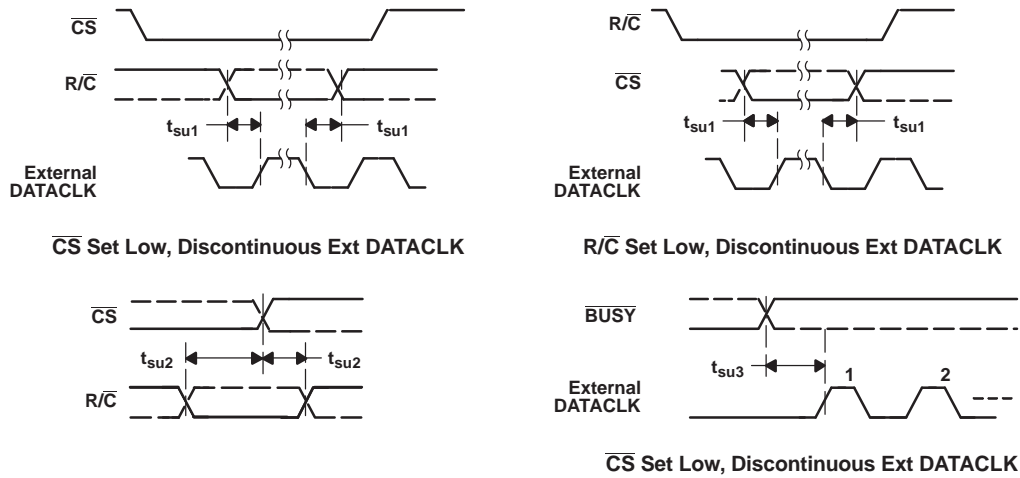

Figure 1. Critical Timing

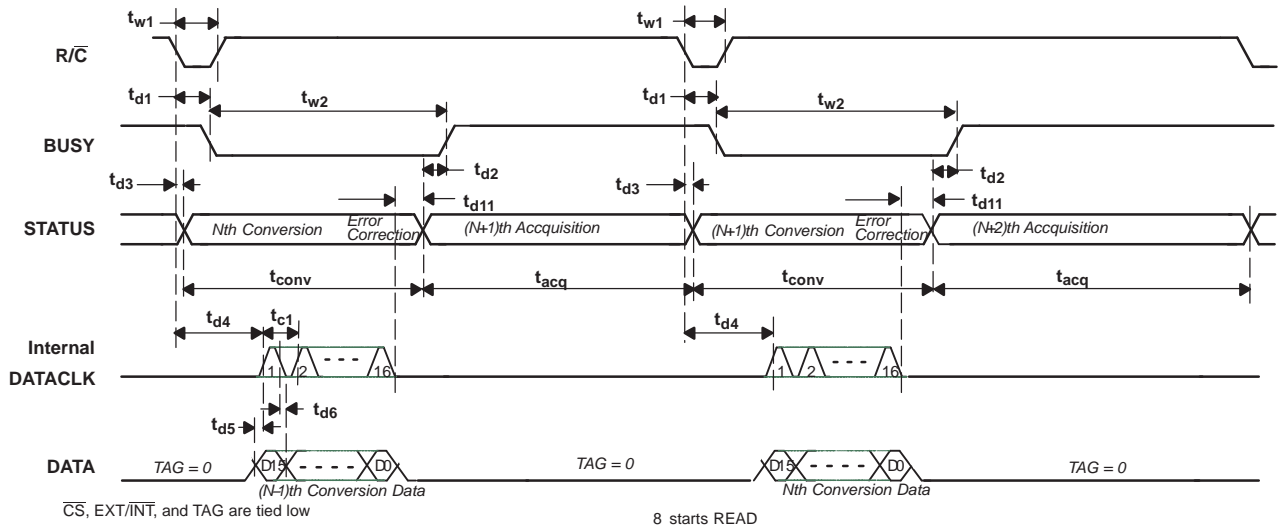

Figure 2. Basic Conversion Timing (Internal DATACLK - Read Previous Data During Conversion)

PARAMETER MEASUREMENT INFORMATION (continued)

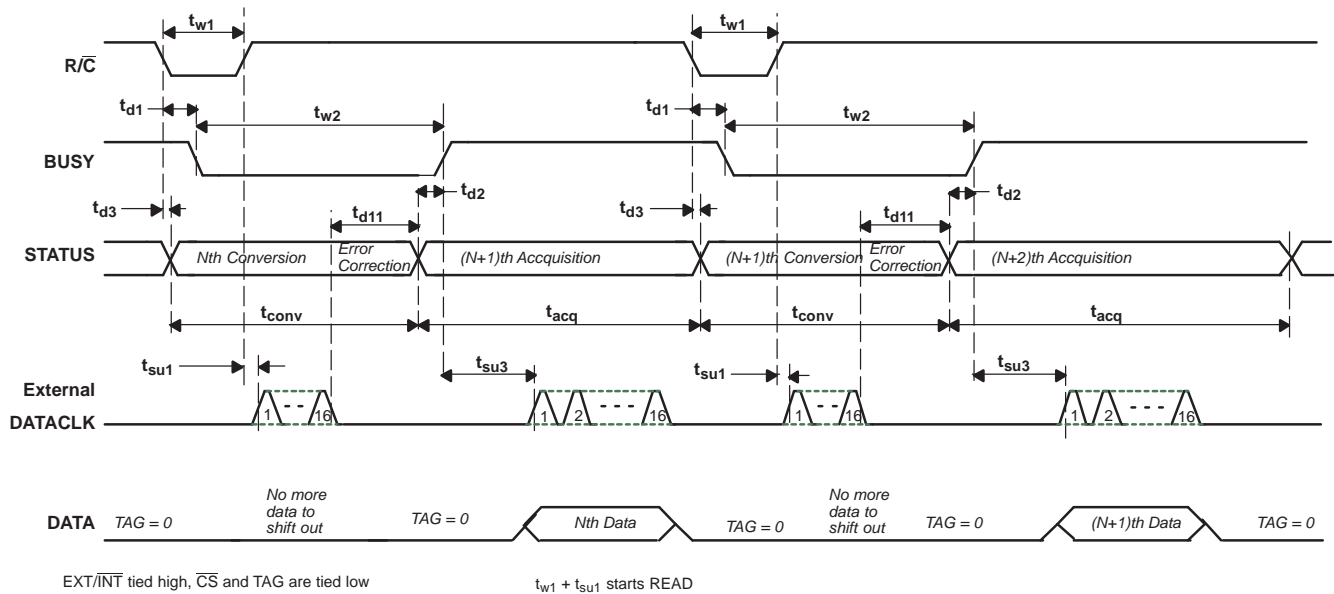

Figure 3. Basic Conversion Timing (External DATACLK)

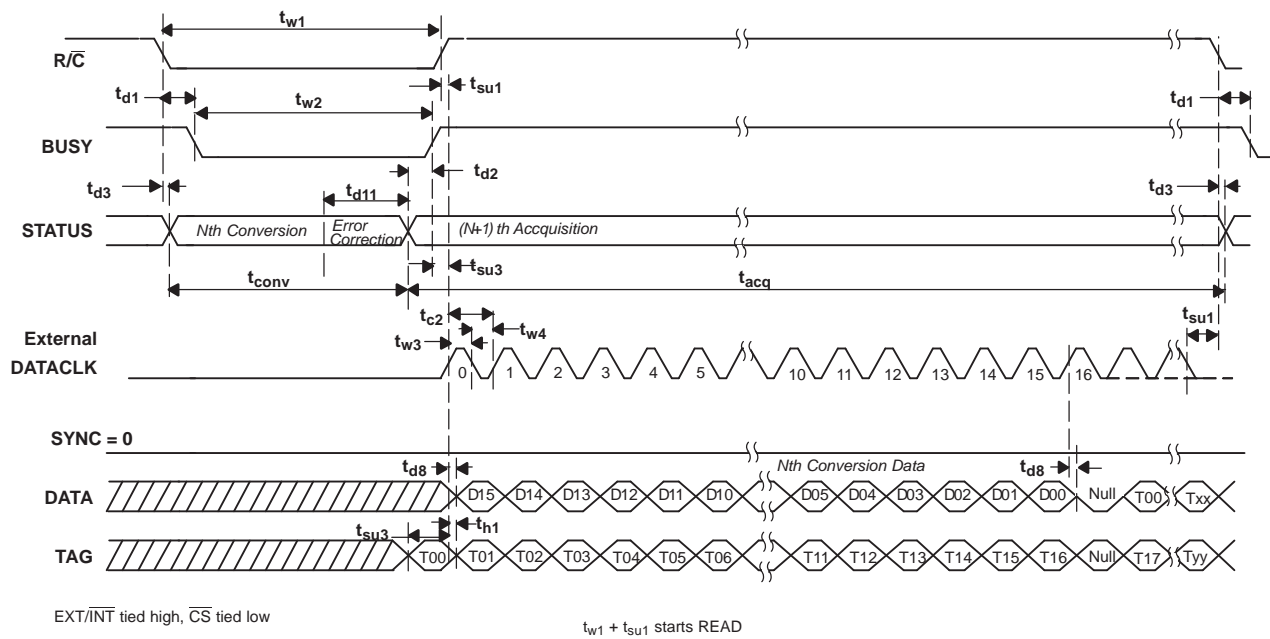

Figure 4. Read After Conversion (Discontinuous External DATACLK)

PARAMETER MEASUREMENT INFORMATION (continued)

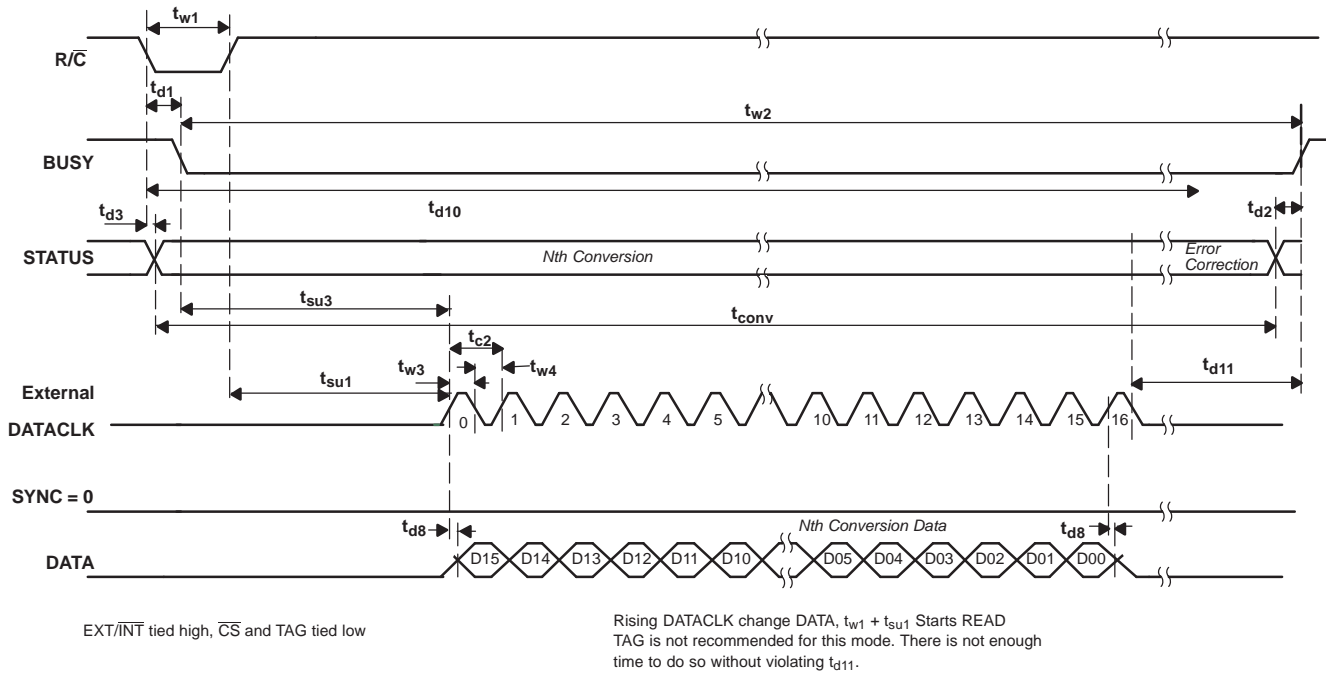

Figure 5. Read During Conversion (Discontinuous External DATACLK)

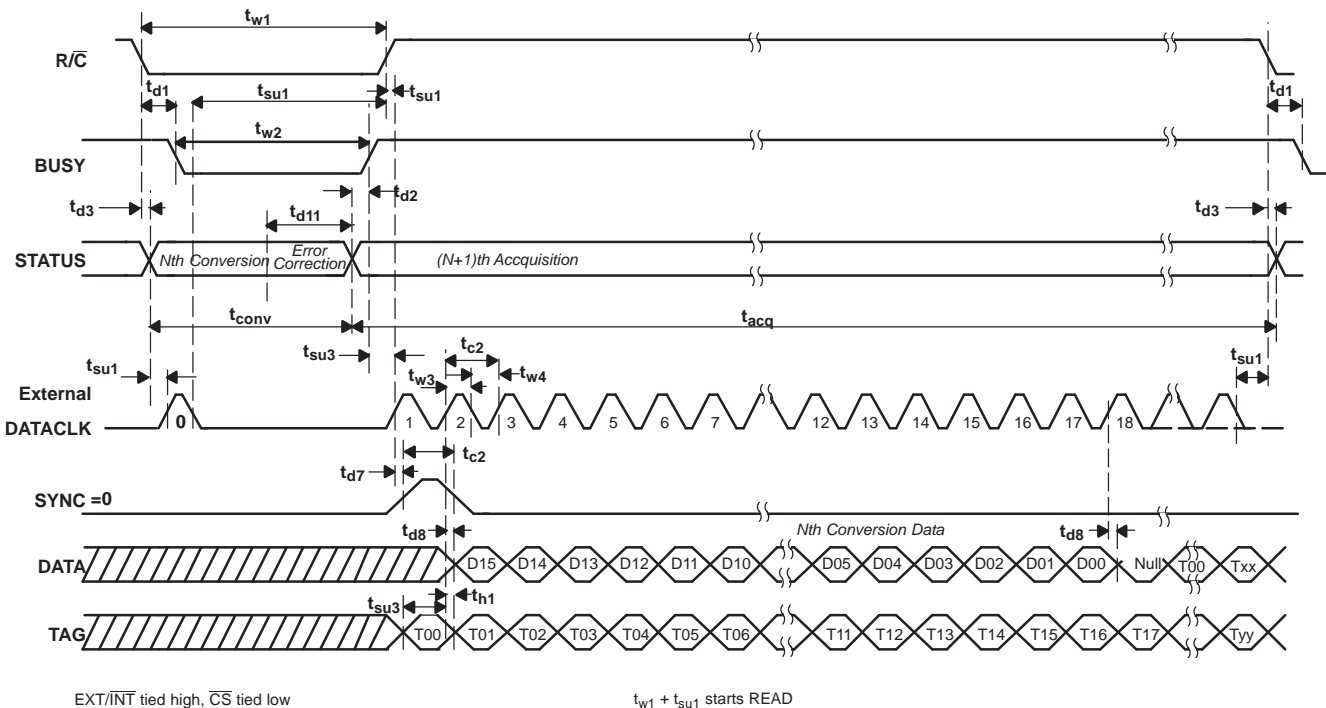
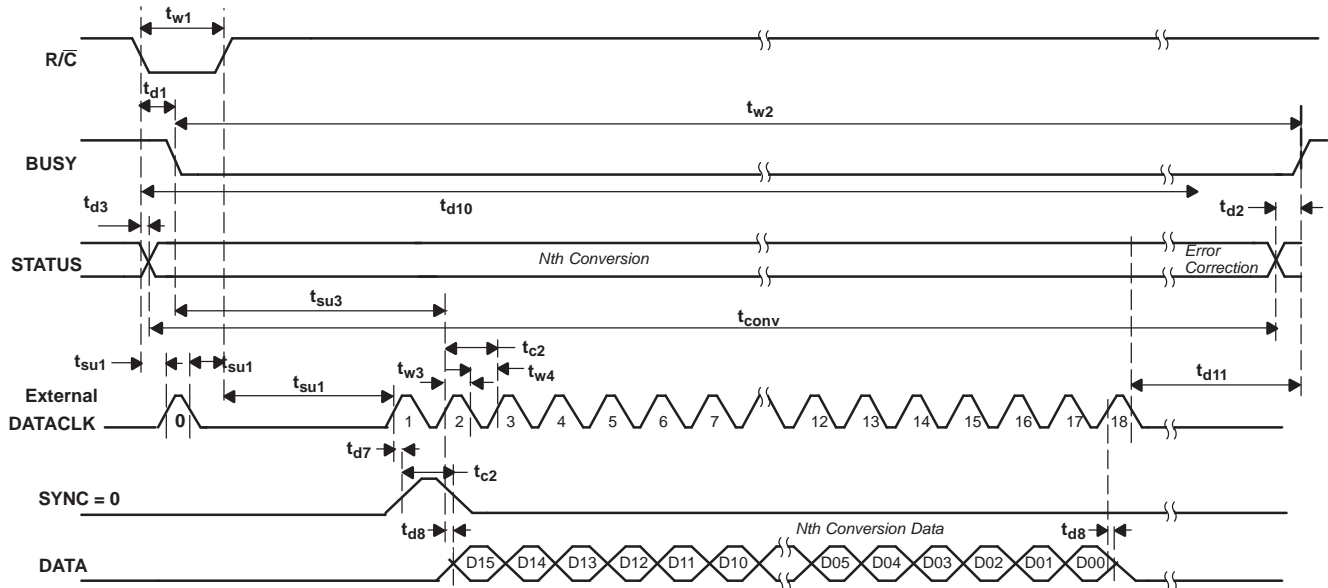

Figure 6. Read After Conversion With SYNC (Discontinuous External DATACLK)

PARAMETER MEASUREMENT INFORMATION (continued)



EXT/INT tied high, CS and TAG tied low

$t_{w1} + t_{su1}$ Starts READ
TAG is not recommended for this mode. There is not enough time to do so without violating t_{d11} .

Figure 7. Read During Conversion With SYNC (Discontinuous External DATACLK)

PARAMETER MEASUREMENT INFORMATION (continued)

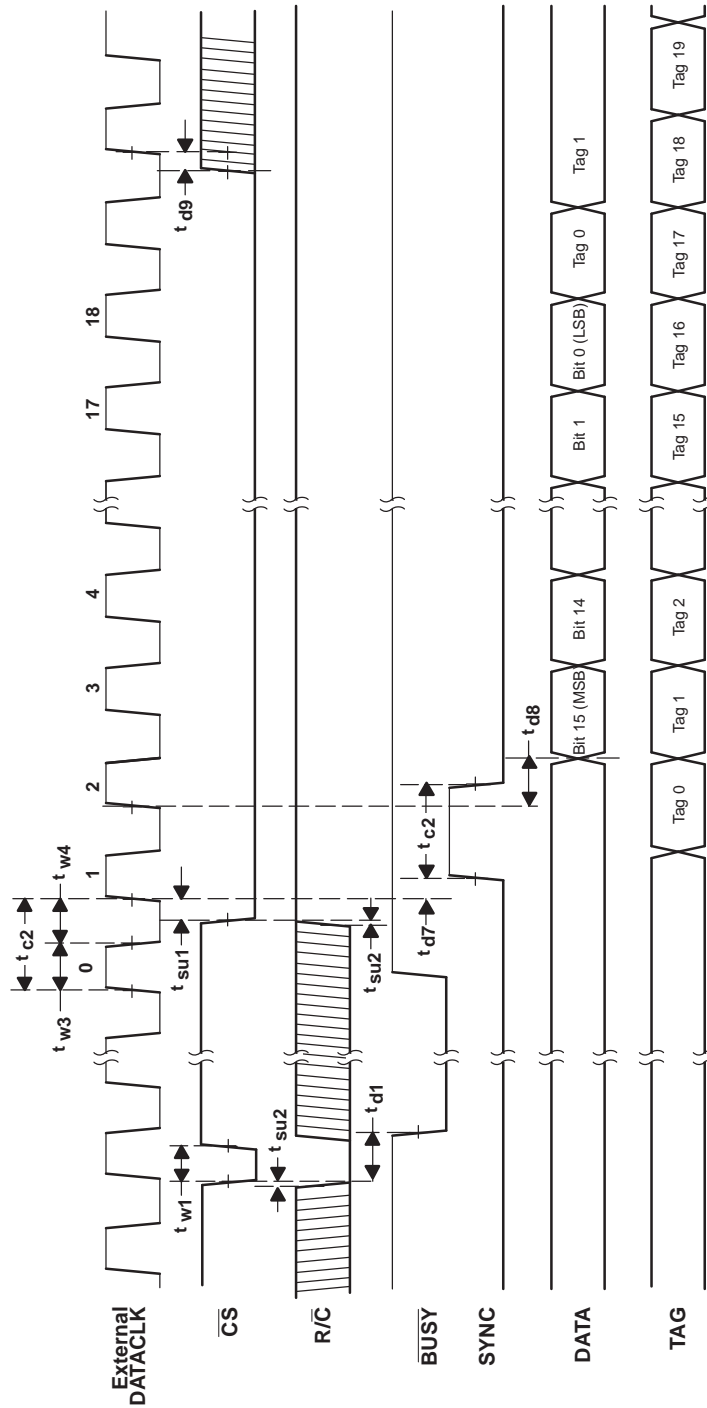

Figure 8. Conversion and Read Timing with Continuous External DATACLK (EXT/INT Tied High) Read After Conversions (Not Recommended)

PARAMETER MEASUREMENT INFORMATION (continued)

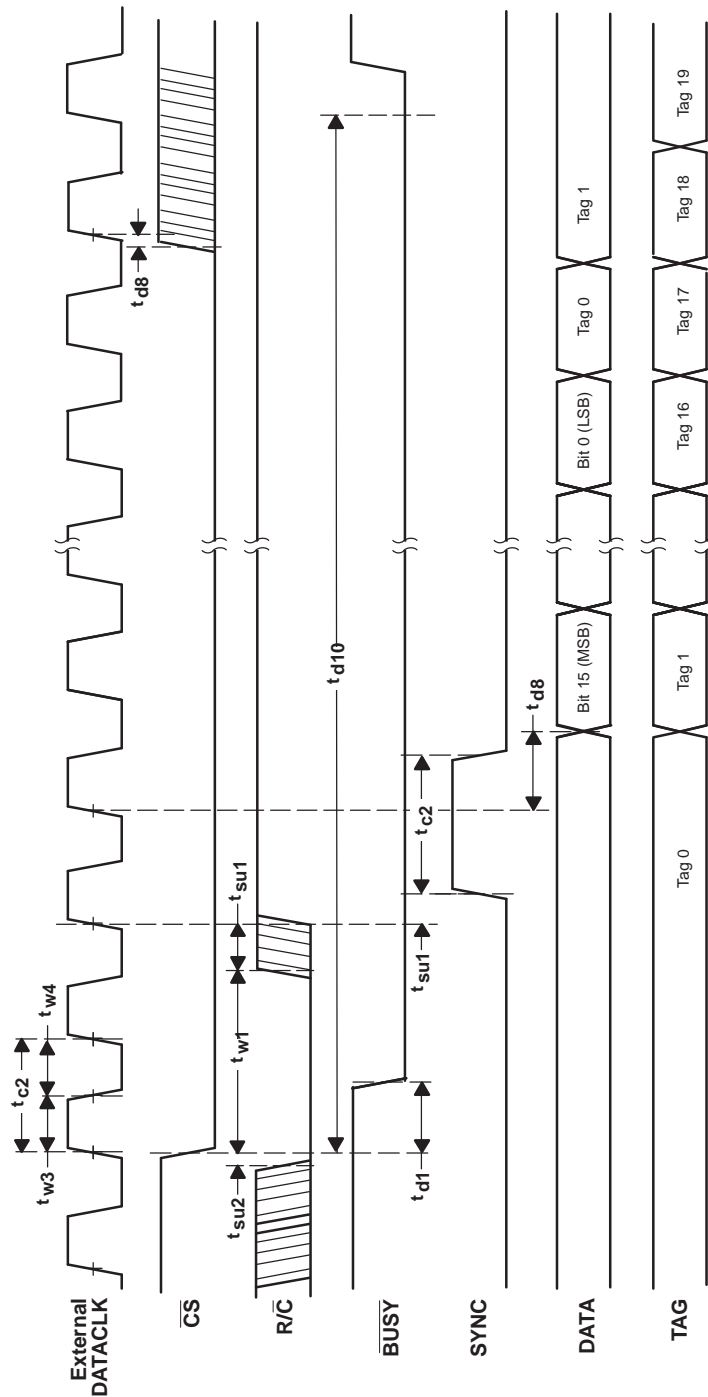

Figure 9. Conversion and Read Timing with Continuous External DATACLK (EXT/INT Tied High) Read Previous Conversion Results During Conversion (Not Recommended)

TYPICAL CHARACTERISTICS

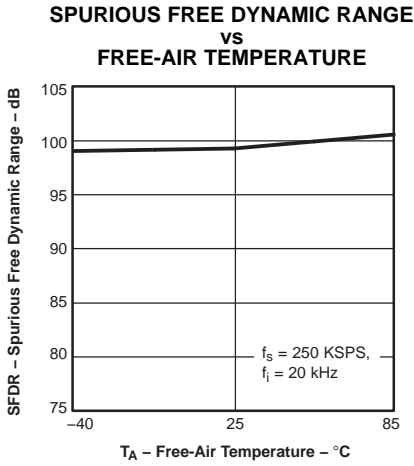

Figure 10.

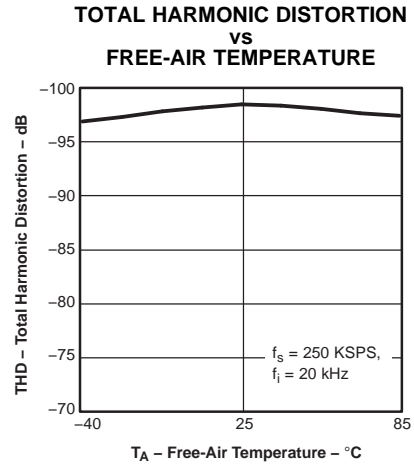

Figure 11.

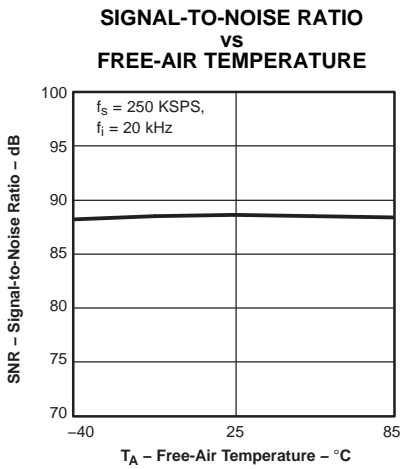

Figure 12.

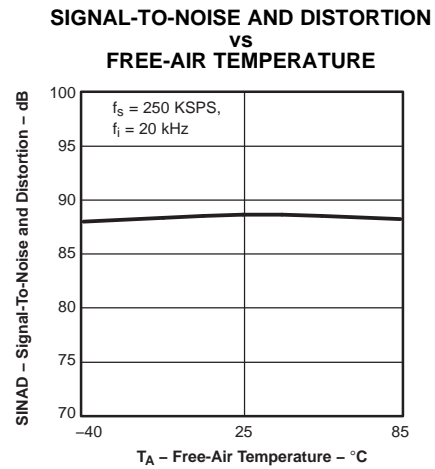

Figure 13.

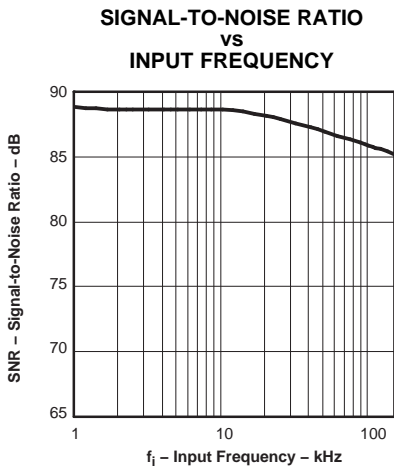

Figure 14.

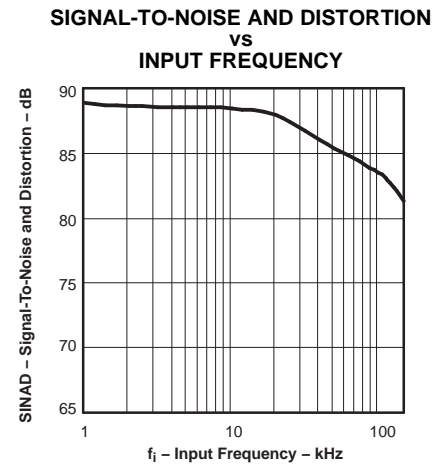

Figure 15.

TYPICAL CHARACTERISTICS (continued)

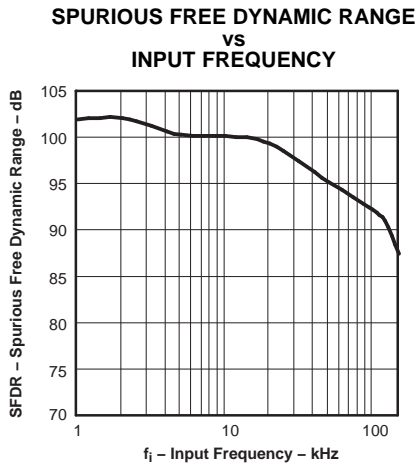

Figure 16.

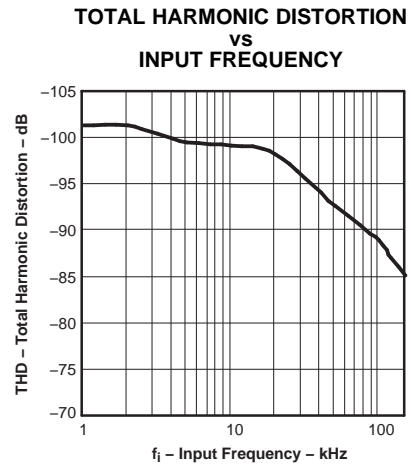

Figure 17.

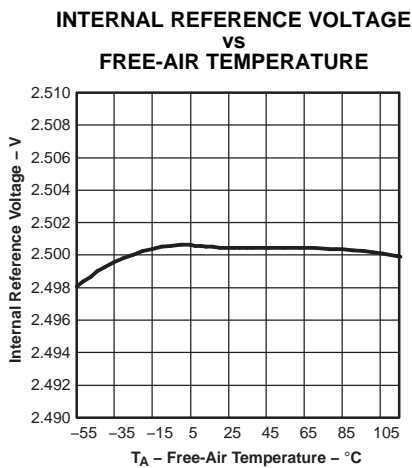

Figure 18.

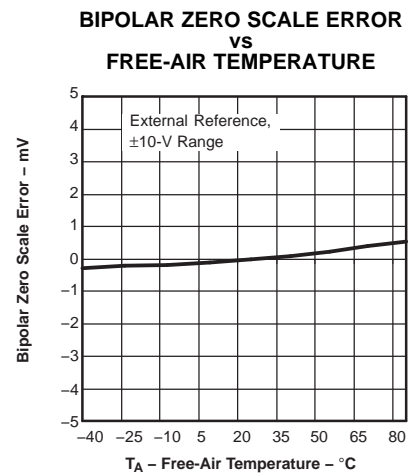

Figure 19.

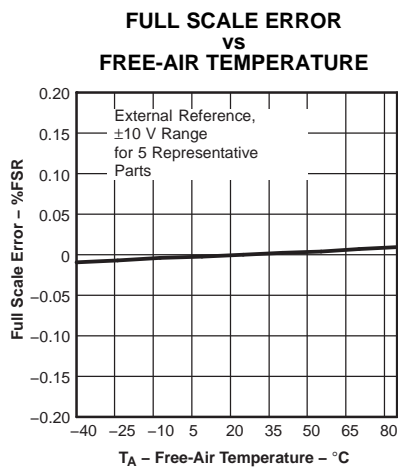

Figure 20.

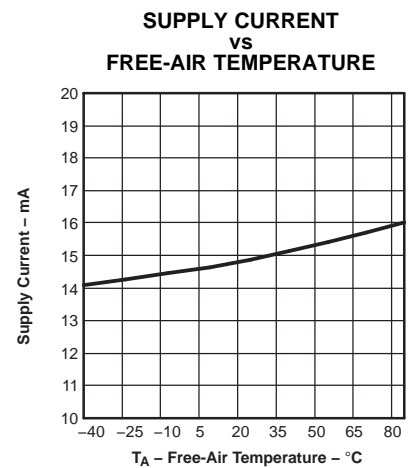

Figure 21.

TYPICAL CHARACTERISTICS (continued)

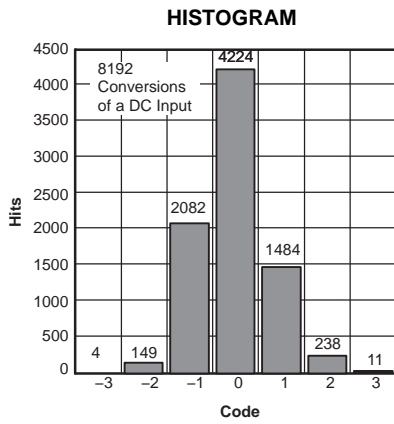

Figure 22.

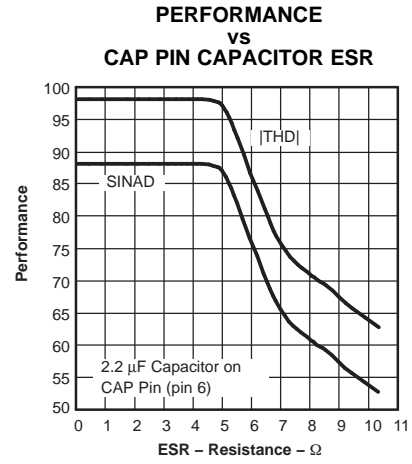

Figure 23.

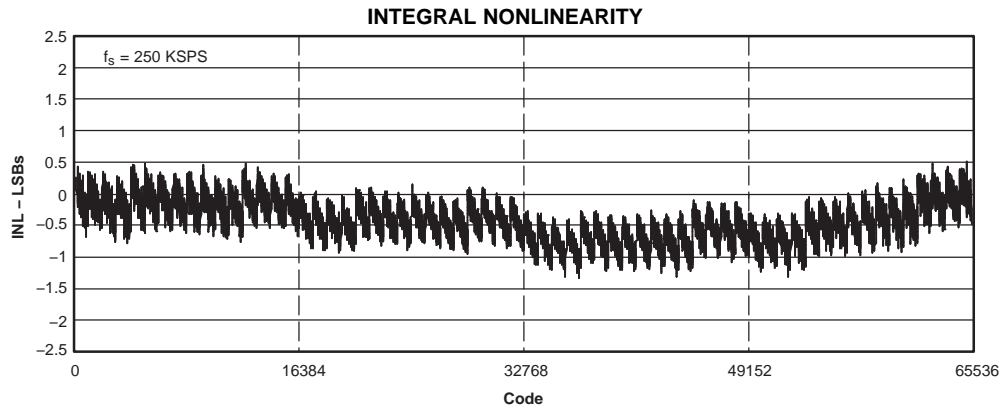

Figure 24.

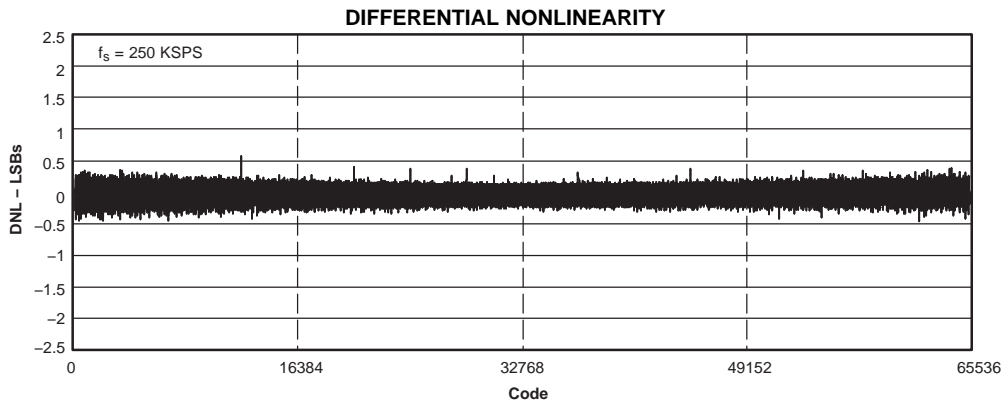

Figure 25.

TYPICAL CHARACTERISTICS (continued)

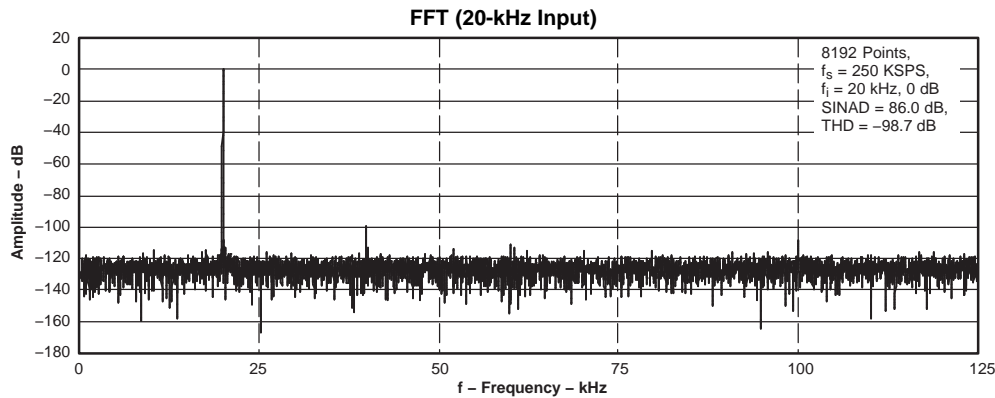

Figure 26.

BASIC OPERATION

Two signals control conversion in the ADS8509: \overline{CS} and R/\overline{C} . These two signals are internally ORed together. To start a conversion the chip must be selected, \overline{CS} low, and the conversion signal must be active, R/\overline{C} low. Either signal can be brought low first. Conversion starts on the falling edge of the second signal. \overline{BUSY} goes low when conversion starts and returns high after the data from that conversion is shifted into the internal storage register. Sampling begins when \overline{BUSY} goes high.

To reduce the number of control pins \overline{CS} can be tied low permanently. The R/\overline{C} pin now controls conversion and data reading exclusively. In the external clock mode this means that the ADS8509 clocks out data whenever R/\overline{C} is brought high and the external clock is active. In the internal clock mode data is clocked out every convert cycle regardless of the states of \overline{CS} and R/\overline{C} . The ADS8509 provides a TAG input for cascading multiple converters together.

READING DATA

The conversion result is available as soon as \overline{BUSY} returns to high, therefore data always represents the conversion previously completed even when it is read during a conversion. The ADS8509 outputs serial data in either straight binary or binary two's complement format. The SB/\overline{BTC} pin controls the format. Data is shifted out MSB first. The first conversion immediately following a power-up does not produce a valid conversion result.

Data can be clocked out with either the internally generated clock or with an external clock. The EXT/\overline{INT} pin controls this function. If an external clock is used, the TAG input can be used to daisy-chain multiple ADS8509 data pins together.

INTERNAL DATACLK

In internal clock mode data for the previous conversion is clocked out during each conversion period. The internal data clock is synchronized to the internal conversion clock so that it does not interfere with the conversion process.

The DATACLK pin becomes an output when EXT/\overline{INT} is low. 16 Clock pulses are generated at the beginning of each conversion after timing t_8 is satisfied, i.e. only the previous conversion result can be read during conversion. DATACLK returns to low when it is inactive. The 16 bits of serial data are shifted out the DATA pin synchronous to this clock with each bit available on a rising and then a falling edge. The DATA pin returns to the state of the TAG pin input sensed at the start of transmission.

EXTERNAL DATACLK

The external clock mode offers several ways to retrieve conversion results. However, since the external clock cannot be synchronized to the internal conversion clock care must be taken to avoid corrupting the data.

When $\text{EXT}/\overline{\text{INT}}$ is set high, the $\text{R}/\overline{\text{C}}$ and $\overline{\text{CS}}$ signals control the read state. When the read state is initiated, the result from the previously completed conversion is shifted out the DATA pin synchronous to the external clock that is connected to the DATACLK pin. Each bit is available on a falling and then a rising edge. The maximum external clock speed of 28.5 MHz allows data to be shifted out quickly either at the beginning of conversion or the beginning of sampling.

There are several modes of operation available when using an external clock. It is recommended that the external clock run only while reading data. This is discontinuous clock mode. Since the external clock is not synchronized to the internal clock that controls conversion slight changes in the external clock can cause conflicts that can corrupt the conversion process. Specifications with a continuously running external clock cannot be ensured. It is especially important that the external clock does not run during the second half of the conversion cycle (approximately the time period specified by t_{d11} , see the TIMING REQUIREMENTS table).

In discontinuous clock mode data can be read during conversion or during sampling, with or without a SYNC pulse. Data read during conversion must meet the t_{d11} timing specification. Data read during sampling must be complete before starting a conversion.

Whether reading during sampling or during conversion a SYNC pulse is generated whenever at least one rising edge of the external clock occurs while the part is not in the read state. In the *discontinuous external clock with SYNC* mode a SYNC pulse follows the first rising edge after the read command. The data is shifted out after the SYNC pulse. The first rising clock edge after the read command generates a SYNC pulse. The SYNC pulse can be detected on the next falling edge and then the next rising edge. Successively, each bit can be read first on the falling edge and then on the next rising edge. Thus 17 clock pulses after the read command are required to read on the falling edge. 18 Clock pulses are necessary to read on the rising edge.

Table 2. DATACLK Pulses

DESCRIPTION	DATACLK PULSES REQUIRED	
	WITH SYNC	WITHOUT SYNC
Read on falling edge of DATACLK	17	16
Read on rising edge of DATACLK	18	17

If the clock is entirely inactive when not in the read state a SYNC pulse is not generated. In this case the first rising clock edge shifts out the MSB. The MSB can be read on the first falling edge or on the next rising edge. In this *discontinuous external clock mode with no SYNC*, 16 clocks are necessary to read the data on the falling edge and 17 clocks for reading on the rising edge. Data always represents the conversion already completed.

TAG FEATURE

The TAG feature allows the data from multiple ADS8509 converters to be read on a single serial line. The converters are cascaded together using the DATA pins as outputs and the TAG pins as inputs as illustrated in [Figure 27](#). The DATA pin of the last converter drives the processor's serial data input. Data is then shifted through each converter, synchronous to the externally supplied data clock, onto the serial data line. The internal clock cannot be used for this configuration.

The preferred timing uses the discontinuous external data clock during the sampling period. Data must be read during the sampling period because there is not sufficient time to read data from multiple converters during a conversion period without violating the t_{d11} constraint (see the EXTERNAL DATACLOCK section). The sampling period must be sufficiently long to allow all data words to be read before starting a new conversion.

Note, in [Figure 27](#), that a NULL bit separates the data word from each converter. The state of the DATA pin at the end of a READ cycle reflects the state of the TAG pin at the start of the cycle. This is true in all READ modes, including the internal clock mode. For example, when a single converter is used in internal clock mode, the state of the TAG pin determines the state of the DATA pin after all 16 bits have shifted out. When multiple converters are cascaded together, this state forms the NULL bit that separates the words. Thus, with the TAG pin of the first converter grounded as shown in [Figure 27](#) the NULL bit becomes a zero between each data word.

The external reference voltage can vary from 2.3 V to 2.7 V. The reference voltage determines the size of the least significant bit (LSB). The larger reference voltages produce a larger LSB, which can improve SNR. Smaller reference voltages can degrade SNR.

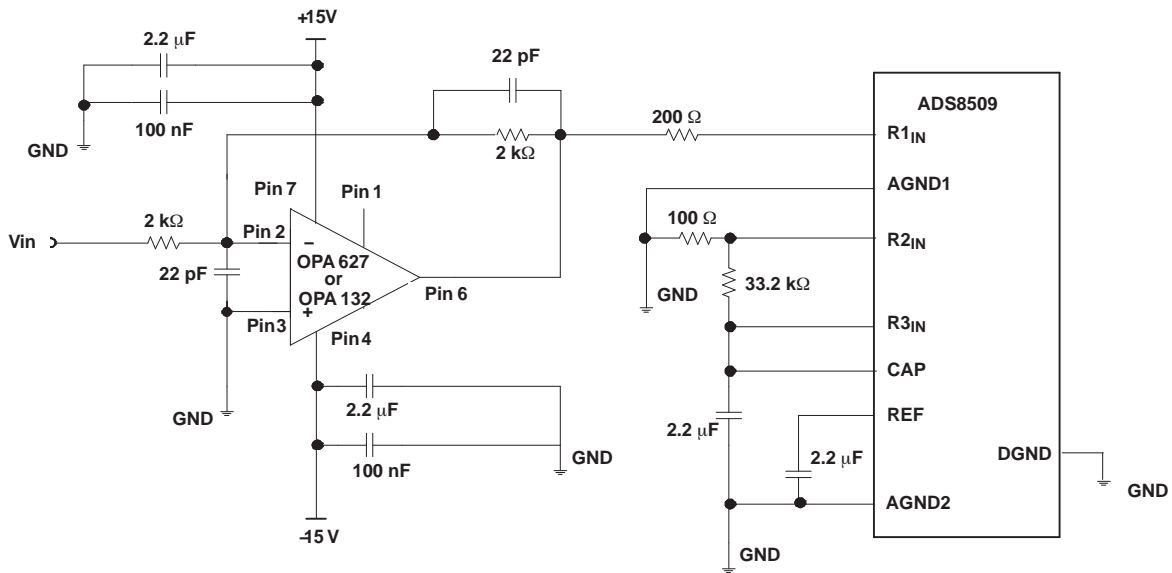

Figure 28. Typical Driving Circuitry (± 10 V, No Trim)

Table 3. Input Range Connections (See Figure 29 and Figure 30 for Complete Information)

ANALOG INPUT RANGE	CONNECT R _{1IN} VIA 200 Ω TO	CONNECT R _{2IN} VIA 100 Ω TO	CONNECT R ₃ TO	IMPEDANCE
±10 V	V _{IN}	AGND	CAP	11.5 kΩ
±5 V	AGND	V _{IN}	CAP	6.7 kΩ
±3.33 V	V _{IN}	V _{IN}	CAP	5.4 kΩ
0 V to 10 V	AGND	V _{IN}	AGND	6.7 kΩ
0 V to 5 V	AGND	AGND	V _{IN}	5.0 kΩ
0 V to 4 V	V _{IN}	AGND	V _{IN}	5.4 kΩ

Table 4. Control Truth Table

SPECIFIC FUNCTION	CS	R/C	BUSY	EXT/INT	DATACLK	PWRD	SB/BTC	OPERATION
Initiate conversion and output data using internal clock	1 > 0	0	1	0	Output	0	x	Initiates conversion <i>n</i> . Data from conversion <i>n</i> - 1 clocked out on DATA synchronized to 16 clock pulses output on DATACLK.
	0	1 > 0	1	0	Output	0	x	
Initiate conversion and output data using external clock	1 > 0	0	1	1	Input	0	x	Initiates conversion <i>n</i> .
	0	1 > 0	1	1	Input	0	x	Initiates conversion <i>n</i> .
	1 > 0	1	1	1	Input	x	x	Outputs data with or without SYNC pulse. See section READING DATA.
	1 > 0	1	0	1	Input	0	x	Outputs data with or without SYNC pulse. See section READING DATA.
	0	0 > 1	0	1	Input	0	x	Outputs data with or without SYNC pulse. See section READING DATA.
No actions	0	0	0 > 1	x	x	0	x	This is an acceptable condition.
Power down	x	x	x	x	x	0	x	Analog circuitry powered. Conversion can proceed..
	x	x	x	x	x	1	x	Analog circuitry disabled. Data from previous conversion maintained in output registers.
Select output format	x	x	x	x	x	x	0	Serial data is output in binary 2's complement format.
	x	x	x	x	x	x	1	Serial data is output in straight binary format.

Table 5. Output Codes and Ideal Input Voltages

DESCRIPTION	ANALOG INPUT						DIGITAL OUTPUT			
							BINARY 2'S COMPLEMENT (SB/BTC LOW)		STRAIGHT BINARY (SB/BTC HIGH)	
							BINARY CODE	HEX CODE	BINARY CODE	HEX CODE
Full-scale range	±10	±5	±3.33 V	0 V to 10 V	0 V to 5 V	0 V to 4 V				
Least significant bit (LSB)	305 μV	153 μV	102 μV	153 μV	76 μV	61 μV				
Full scale (FS - 1LSB)	9.999695 V	4.999847 V	3.333231 V	9.999847 V	4.999924 V	3.999939 V	0111 1111 1111 1111	7FFF	1111 1111 1111 1111	FFFF
Midscale	0 V	0 V	0 V	5 V	2.5 V	2 V	0000 0000 0000 0000	0000	1000 0000 0000 0000	8000
One LSB below midscale	-305 μV	153 μV	±102 μV	4.999847 V	2.499924 V	1.999939 V	1111 1111 1111 1111	FFFF	0111 1111 1111 1111	7FFF
-Full scale	-10 V	-5 V	-3.333333 V	0 V	0 V	0 V	1000 0000 0000 0000	8000	0000 0000 0000 0000	0000

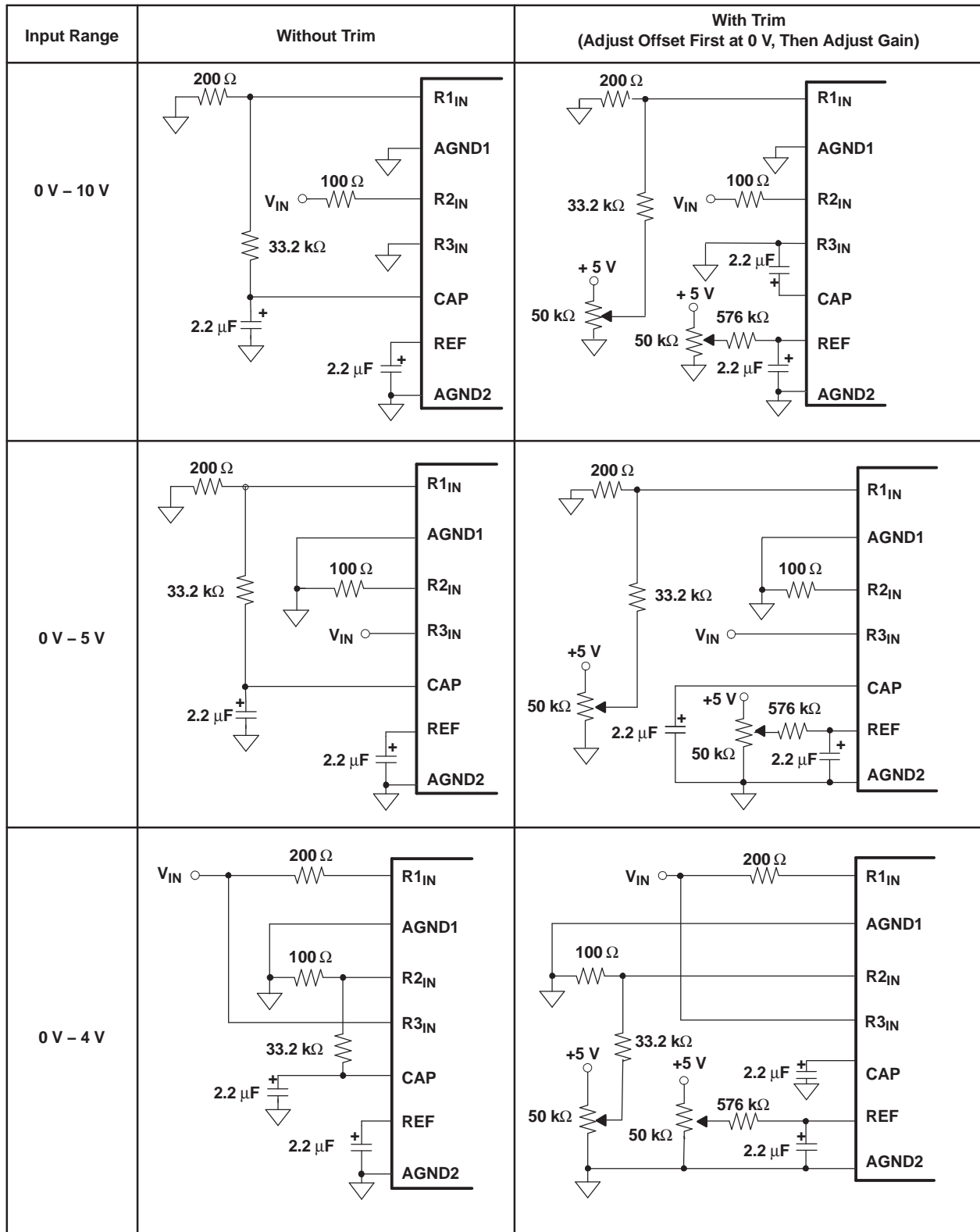

Figure 29. Offset/Gain Circuits for Unipolar Input Ranges

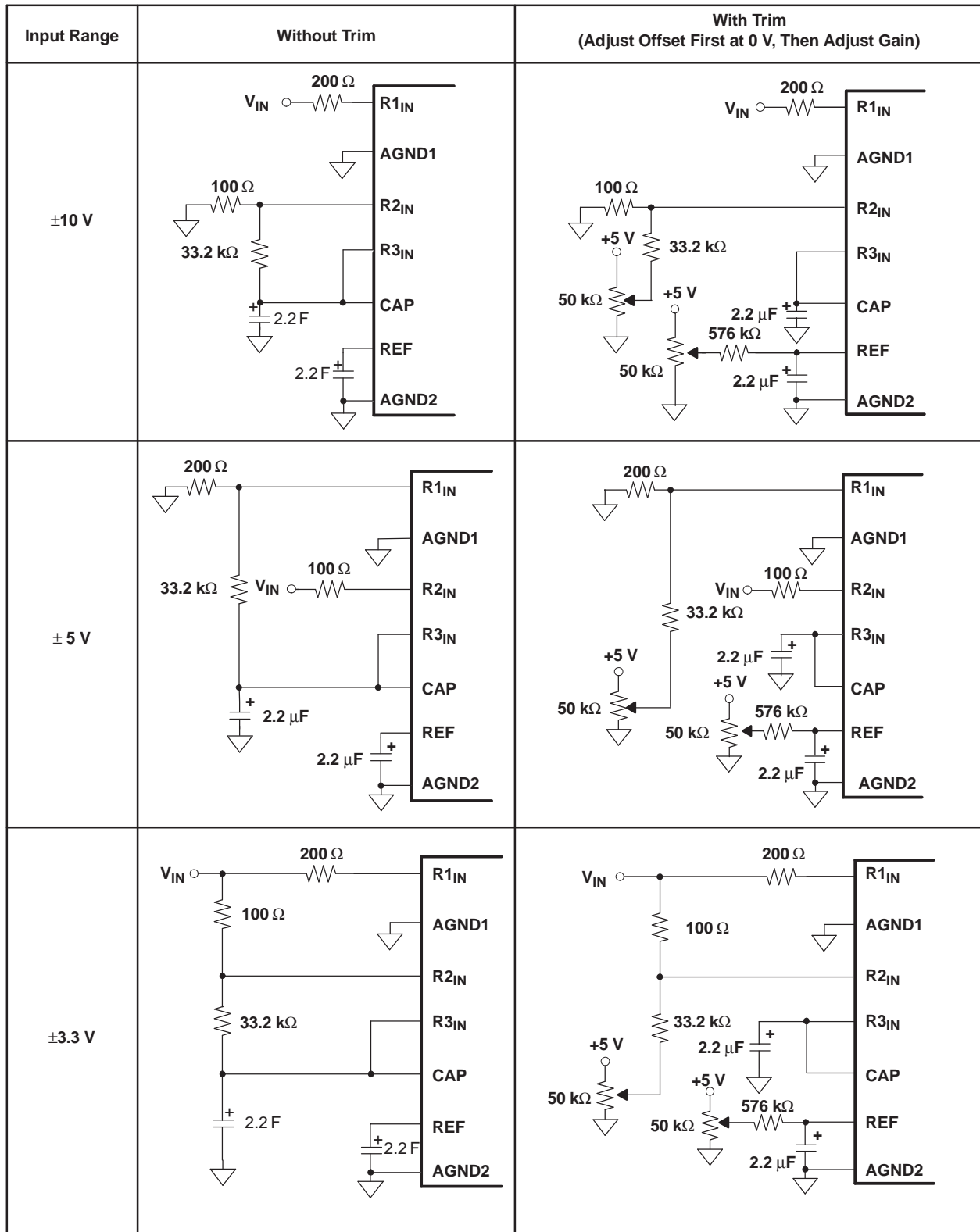

Figure 30. Offset/Gain Circuits for Bipolar Input Ranges

PACKAGING INFORMATION

Orderable Device	Status ⁽¹⁾	Package Type	Package Drawing	Pins	Package Qty	Eco Plan ⁽²⁾	Lead/Ball Finish	MSL Peak Temp ⁽³⁾
ADS8509IBDB	ACTIVE	SSOP	DB	28	50	Green (RoHS & no Sb/Br)	CU NIPDAU	Level-2-260C-1 YEAR
ADS8509IBDBG4	ACTIVE	SSOP	DB	28	50	Green (RoHS & no Sb/Br)	CU NIPDAU	Level-2-260C-1 YEAR
ADS8509IBDBR	ACTIVE	SSOP	DB	28	2000	Green (RoHS & no Sb/Br)	CU NIPDAU	Level-2-260C-1 YEAR
ADS8509IBDBRG4	ACTIVE	SSOP	DB	28	2000	Green (RoHS & no Sb/Br)	CU NIPDAU	Level-2-260C-1 YEAR
ADS8509IBDW	ACTIVE	SOIC	DW	20	25	Green (RoHS & no Sb/Br)	CU NIPDAU	Level-2-260C-1 YEAR
ADS8509IBDWG4	ACTIVE	SOIC	DW	20	25	Green (RoHS & no Sb/Br)	CU NIPDAU	Level-2-260C-1 YEAR
ADS8509IBDWR	ACTIVE	SOIC	DW	20	2000	Green (RoHS & no Sb/Br)	CU NIPDAU	Level-2-260C-1 YEAR
ADS8509IBDWRG4	ACTIVE	SOIC	DW	20	2000	Green (RoHS & no Sb/Br)	CU NIPDAU	Level-2-260C-1 YEAR
ADS8509IDB	ACTIVE	SSOP	DB	28	50	Green (RoHS & no Sb/Br)	CU NIPDAU	Level-2-260C-1 YEAR
ADS8509IDBG4	ACTIVE	SSOP	DB	28	50	Green (RoHS & no Sb/Br)	CU NIPDAU	Level-2-260C-1 YEAR
ADS8509IDBR	ACTIVE	SSOP	DB	28	2000	Green (RoHS & no Sb/Br)	CU NIPDAU	Level-2-260C-1 YEAR
ADS8509IDBRG4	ACTIVE	SSOP	DB	28	2000	Green (RoHS & no Sb/Br)	CU NIPDAU	Level-2-260C-1 YEAR
ADS8509IDW	ACTIVE	SOIC	DW	20	25	Green (RoHS & no Sb/Br)	CU NIPDAU	Level-2-260C-1 YEAR
ADS8509IDWG4	ACTIVE	SOIC	DW	20	25	Green (RoHS & no Sb/Br)	CU NIPDAU	Level-2-260C-1 YEAR
ADS8509IDWR	ACTIVE	SOIC	DW	20	2000	Green (RoHS & no Sb/Br)	CU NIPDAU	Level-2-260C-1 YEAR
ADS8509IDWRG4	ACTIVE	SOIC	DW	20	2000	Green (RoHS & no Sb/Br)	CU NIPDAU	Level-2-260C-1 YEAR

⁽¹⁾ The marketing status values are defined as follows:

ACTIVE: Product device recommended for new designs.

LIFEBUY: TI has announced that the device will be discontinued, and a lifetime-buy period is in effect.

NRND: Not recommended for new designs. Device is in production to support existing customers, but TI does not recommend using this part in a new design.

PREVIEW: Device has been announced but is not in production. Samples may or may not be available.

OBSOLETE: TI has discontinued the production of the device.

⁽²⁾ Eco Plan - The planned eco-friendly classification: Pb-Free (RoHS), Pb-Free (RoHS Exempt), or Green (RoHS & no Sb/Br) - please check <http://www.ti.com/productcontent> for the latest availability information and additional product content details.

TBD: The Pb-Free/Green conversion plan has not been defined.

Pb-Free (RoHS): TI's terms "Lead-Free" or "Pb-Free" mean semiconductor products that are compatible with the current RoHS requirements for all 6 substances, including the requirement that lead not exceed 0.1% by weight in homogeneous materials. Where designed to be soldered at high temperatures, TI Pb-Free products are suitable for use in specified lead-free processes.

Pb-Free (RoHS Exempt): This component has a RoHS exemption for either 1) lead-based flip-chip solder bumps used between the die and package, or 2) lead-based die adhesive used between the die and leadframe. The component is otherwise considered Pb-Free (RoHS compatible) as defined above.

Green (RoHS & no Sb/Br): TI defines "Green" to mean Pb-Free (RoHS compatible), and free of Bromine (Br) and Antimony (Sb) based flame retardants (Br or Sb do not exceed 0.1% by weight in homogeneous material)

⁽³⁾ MSL, Peak Temp. -- The Moisture Sensitivity Level rating according to the JEDEC industry standard classifications, and peak solder temperature.

Important Information and Disclaimer:The information provided on this page represents TI's knowledge and belief as of the date that it is provided. TI bases its knowledge and belief on information provided by third parties, and makes no representation or warranty as to the accuracy of such information. Efforts are underway to better integrate information from third parties. TI has taken and continues to take reasonable steps to provide representative and accurate information but may not have conducted destructive testing or chemical analysis on incoming materials and chemicals. TI and TI suppliers consider certain information to be proprietary, and thus CAS numbers and other limited information may not be available for release.

In no event shall TI's liability arising out of such information exceed the total purchase price of the TI part(s) at issue in this document sold by TI to Customer on an annual basis.

TAPE AND REEL INFORMATION



QUADRANT ASSIGNMENTS FOR PIN 1 ORIENTATION IN TAPE

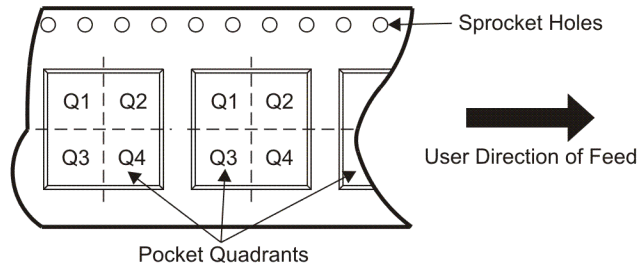

*All dimensions are nominal

Device	Package Type	Package Drawing	Pins	SPQ	Reel Diameter (mm)	Reel Width W1 (mm)	A0 (mm)	B0 (mm)	K0 (mm)	P1 (mm)	W (mm)	Pin1 Quadrant
ADS8509IBDBR	SSOP	DB	28	2000	330.0	16.4	8.1	10.4	2.5	12.0	16.0	Q1
ADS8509IBDWR	SOIC	DW	20	2000	330.0	24.4	10.8	13.1	2.65	12.0	24.0	Q1
ADS8509IDBR	SSOP	DB	28	2000	330.0	16.4	8.1	10.4	2.5	12.0	16.0	Q1
ADS8509IDWR	SOIC	DW	20	2000	330.0	24.4	10.8	13.1	2.65	12.0	24.0	Q1

TAPE AND REEL BOX DIMENSIONS



*All dimensions are nominal

Device	Package Type	Package Drawing	Pins	SPQ	Length (mm)	Width (mm)	Height (mm)
ADS8509IBDBR	SSOP	DB	28	2000	346.0	346.0	33.0
ADS8509IBDWR	SOIC	DW	20	2000	346.0	346.0	41.0
ADS8509IDBR	SSOP	DB	28	2000	346.0	346.0	33.0
ADS8509IDWR	SOIC	DW	20	2000	346.0	346.0	41.0

DW (R-PDSO-G20)

PLASTIC SMALL-OUTLINE PACKAGE

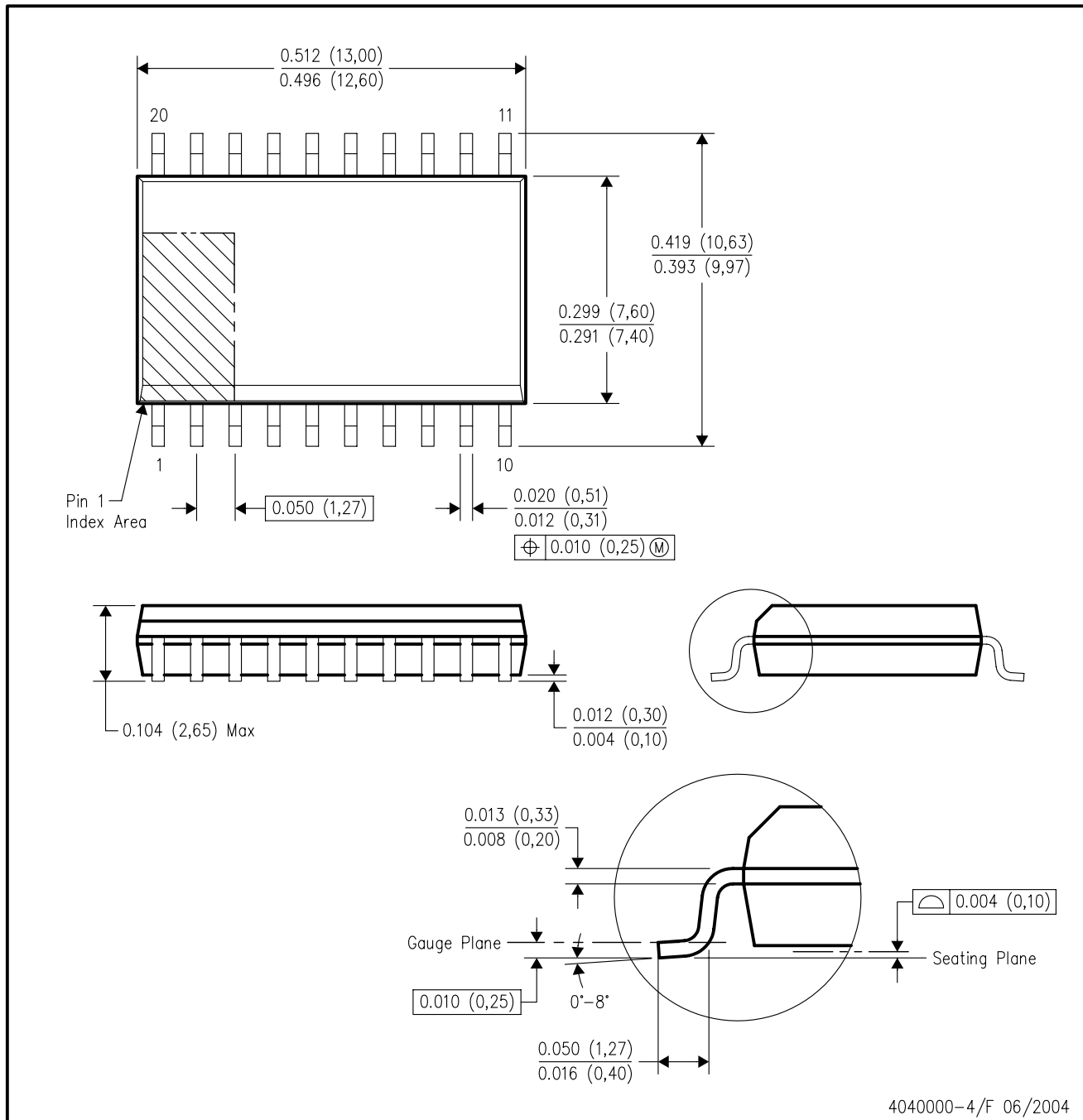

- NOTES:
- A. All linear dimensions are in inches (millimeters).
 - B. This drawing is subject to change without notice.
 - C. Body dimensions do not include mold flash or protrusion not to exceed 0.006 (0,15).
 - D. Falls within JEDEC MS-013 variation AC.

IMPORTANT NOTICE

Texas Instruments Incorporated and its subsidiaries (TI) reserve the right to make corrections, modifications, enhancements, improvements, and other changes to its products and services at any time and to discontinue any product or service without notice. Customers should obtain the latest relevant information before placing orders and should verify that such information is current and complete. All products are sold subject to TI's terms and conditions of sale supplied at the time of order acknowledgment.

TI warrants performance of its hardware products to the specifications applicable at the time of sale in accordance with TI's standard warranty. Testing and other quality control techniques are used to the extent TI deems necessary to support this warranty. Except where mandated by government requirements, testing of all parameters of each product is not necessarily performed.

TI assumes no liability for applications assistance or customer product design. Customers are responsible for their products and applications using TI components. To minimize the risks associated with customer products and applications, customers should provide adequate design and operating safeguards.

TI does not warrant or represent that any license, either express or implied, is granted under any TI patent right, copyright, mask work right, or other TI intellectual property right relating to any combination, machine, or process in which TI products or services are used. Information published by TI regarding third-party products or services does not constitute a license from TI to use such products or services or a warranty or endorsement thereof. Use of such information may require a license from a third party under the patents or other intellectual property of the third party, or a license from TI under the patents or other intellectual property of TI.

Reproduction of TI information in TI data books or data sheets is permissible only if reproduction is without alteration and is accompanied by all associated warranties, conditions, limitations, and notices. Reproduction of this information with alteration is an unfair and deceptive business practice. TI is not responsible or liable for such altered documentation. Information of third parties may be subject to additional restrictions.

Resale of TI products or services with statements different from or beyond the parameters stated by TI for that product or service voids all express and any implied warranties for the associated TI product or service and is an unfair and deceptive business practice. TI is not responsible or liable for any such statements.

TI products are not authorized for use in safety-critical applications (such as life support) where a failure of the TI product would reasonably be expected to cause severe personal injury or death, unless officers of the parties have executed an agreement specifically governing such use. Buyers represent that they have all necessary expertise in the safety and regulatory ramifications of their applications, and acknowledge and agree that they are solely responsible for all legal, regulatory and safety-related requirements concerning their products and any use of TI products in such safety-critical applications, notwithstanding any applications-related information or support that may be provided by TI. Further, Buyers must fully indemnify TI and its representatives against any damages arising out of the use of TI products in such safety-critical applications.

TI products are neither designed nor intended for use in military/aerospace applications or environments unless the TI products are specifically designated by TI as military-grade or "enhanced plastic." Only products designated by TI as military-grade meet military specifications. Buyers acknowledge and agree that any such use of TI products which TI has not designated as military-grade is solely at the Buyer's risk, and that they are solely responsible for compliance with all legal and regulatory requirements in connection with such use.

TI products are neither designed nor intended for use in automotive applications or environments unless the specific TI products are designated by TI as compliant with ISO/TS 16949 requirements. Buyers acknowledge and agree that, if they use any non-designated products in automotive applications, TI will not be responsible for any failure to meet such requirements.

Following are URLs where you can obtain information on other Texas Instruments products and application solutions:

Products

Amplifiers	amplifier.ti.com
Data Converters	dataconverter.ti.com
DSP	dsp.ti.com
Clocks and Timers	www.ti.com/clocks
Interface	interface.ti.com
Logic	logic.ti.com
Power Mgmt	power.ti.com
Microcontrollers	microcontroller.ti.com
RFID	www.ti-rfid.com
RF/IF and ZigBee® Solutions	www.ti.com/lprf

Applications

Audio	www.ti.com/audio
Automotive	www.ti.com/automotive
Broadband	www.ti.com/broadband
Digital Control	www.ti.com/digitalcontrol
Medical	www.ti.com/medical
Military	www.ti.com/military
Optical Networking	www.ti.com/opticalnetwork
Security	www.ti.com/security
Telephony	www.ti.com/telephony
Video & Imaging	www.ti.com/video
Wireless	www.ti.com/wireless

Mailing Address: Texas Instruments, Post Office Box 655303, Dallas, Texas 75265
Copyright © 2008, Texas Instruments Incorporated